



8261 State Route 235
Dayton, Ohio 45424 USA
Phone: (937) 482-0200
Fax: (937) 482-0030
www.apache-laser.com



Warranty

Thank you for purchasing our product. Your VERTEX™ Laser System is a premium quality tool that has been designed and manufactured to provide years of reliable performance.

This manual is an important part of your purchase as it will familiarize you with the unit and explain the numerous features that have been designed into it. Please read this manual thoroughly before using your laser system.

Please contact your Apache dealer or the Apache factory should you have questions regarding specific applications or if you require additional information.

Please record your product information below. This will assist you if there are any questions regarding warranty or service.

PRODUCT: _____

SERIAL NUMBERS: _____

DATE OF PURCHASE: _____

PURCHASED FROM: _____

PHONE: _____

The VERTEX slope laser is warranted for thirty-six (36) months from the date of new equipment purchase from an authorized dealer. During the warranty period, the manufacturer, or its authorized service center, will repair or replace, at the manufacturer's sole discretion, the laser, free of charge, (except for transportation costs) if the products are found by the manufacturer, or its authorized service center, to be defective in either materials or workmanship. The 36 month warranty also covers the internal leveling mechanism and internal optics against damage from any cause.

Maintaining the calibration of the product is not the responsibility of the manufacturer or its authorized service centers. If service is needed, the product(s) must be sent FREIGHT PREPAID to the nearest authorized service center or to the manufacturer.

Safety Labels and Locations

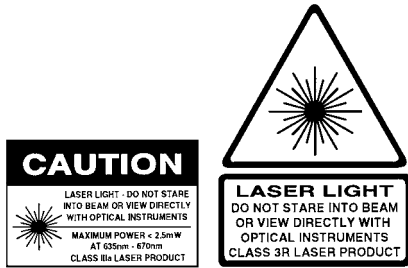

CDRH /IEC Warning Logotype
(Located on side of top cap)

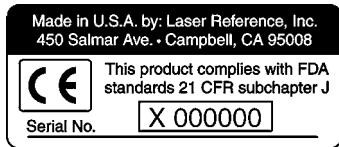

Serial / CDRH / IEC compliance
(Located under main housing)



Aperture Warning
(Located on control panel underneath output window)



Charger Warning
(Located next to charge input)

A warning placard is included with each laser and can be attached to the outside of the carrying case. The case can then be placed in a visible location near where the laser is being used in order to meet jobsite posting requirements.

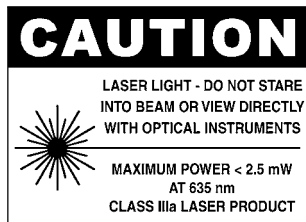

(CDRH)

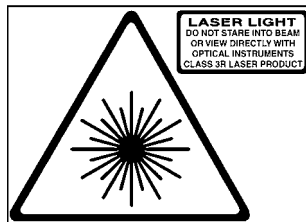

(IEC)

CONTENTS

VERTEX Slope Laser System

System Description	2
Controls and Displays	2
Battery Installation	4
Operation - Initial Setup	5
Level Setup	6
Slope Setup	6
Compound Slope Setup	8
Maintenance and Care	10
Calibration	11
Troubleshooting	13
Specifications	14
Laser Safety	15
Safety Labels	16
Warranty	17

VERTEX Slope Laser System

System Description

The VERTEX Slope Laser System is a one-man leveling tool that allows one person to take accurate, self-leveled elevation measurements up to 1600 feet away from the transmitter. The laser can be operated for flat work or a grade can be set for sloped work. A compound grade (dual slope) can be set with the compound grade adapter.

The laser signal is rotated in a 360° plane. The hand held or rod mounted laser detector reads the laser signal. The detector indicates the Hi / Low / On-Grade elevation via a visual display on front and rear LCD's and also with audible tones. Please refer to the detector operating manual for details.

The VERTEX Laser System is designed for all general construction and agricultural leveling tasks. Set the transmitter up on a central location to provide a continuous elevation reference. This reference can be used by multiple persons for a variety of leveling applications with additional laser detectors.

Controls and Displays

1. **Slope Adjustment Knob** - Used to set slope into the laser, or to set the laser to level (0 slope).
2. **Slope Counter** - Displays the slope that is set into the laser. Resolution is 0.01%
3. **Low Battery Indicator** - Yellow LED indicates the batteries need to be replaced or charged.
4. **Power On Indicator** - Green LED indicates the laser is on.
5. **Slope Alignment Sights** - used to align the slope axis of the laser when slope is required.
6. **Leveling Indicators / H.I. Alert** - When power is turned on, the upper green LED turns on when the leveling system is active. A constant light indicates the laser is leveling. A flashing light indicates the laser is nearly level. When the laser is fully level, the leveling LED turns off, the green power on LED comes on, and the laser begins to rotate.

If the laser cannot level, a red LED in the lower indicator will flash. This indicates the tripod or surface the laser is on must be more level or closer to the slope that is dialed in.

Safety

Precautions to follow when using any laser.

Do not stare into the laser beam or view it directly with optical instruments.

Do not disassemble the laser or attempt to service it.

Do not use the laser until you have read the instruction manual and you are familiar with how to operate the laser properly.

U.S. OSHA requirements for operating visible lasers.

Only qualified, trained employees may install, adjust and operate the laser.

Laser operators must carry proof of qualification.

The area of a job site where a laser is being used must be posted with a laser warning placard.

The laser should be set up above or below eye level and never intentionally aimed at anyone.

Turn the laser off when it is not being used, such as during lunch hour, at the end of the day, or during other long breaks in the work.

NOTE: The Vertex Laser is a CDRH Class IIIa laser and an IEC 60825 Class 3R laser.

Both models conform to applicable EC directives regarding RFI and EMI and to FDA performance standards 21 CFR subchapter J.

Specifications

Range (with Cyclone)	1650 ft. radius (500 m) 3300 ft. diameter (1000 m)
Accuracy, Flat	±10 arc seconds, or 1/16 in. per 100 ft. (1.6 mm per 30 m)
Accuracy, Grade	0.0-2.0% = ±0.010% 2.0-6.0% = ±0.015% 6.0% + = ±0.040%
Slope Capability	0 to 25%, .01% increments, single axis
Rotational Coverage	360 Degrees
Self-Leveling Range	± 4 Degrees
Slope Display	Digital Counter, 0.01% increments
Rotation Speed	Selectable: 600, 900, 1200 RPM
Power Supply	Four C-Cell batteries
Rechargeable Batteries	Optional Ni-MH
Battery Life: Alkaline	70 hours
Ni-MH	55 hours
Automatic Shut-off	If off-level for more than 3 minutes
Environmental	Dust and water resistant (IP55)
Operating Temperature	14°F to +122°F (-10°C to +50°C)
Storage Temperature	-40°F to +140°F (-40°C to +60°C)
Safety Class	CDRH Class IIIa IEC 825 -1 Class 3R
Height	9.7 in. (24.5 cm)
Weight (Laser only)	4.4 lbs. (2.0 kg)

*Specifications subject to change without notice

Controls and Displays

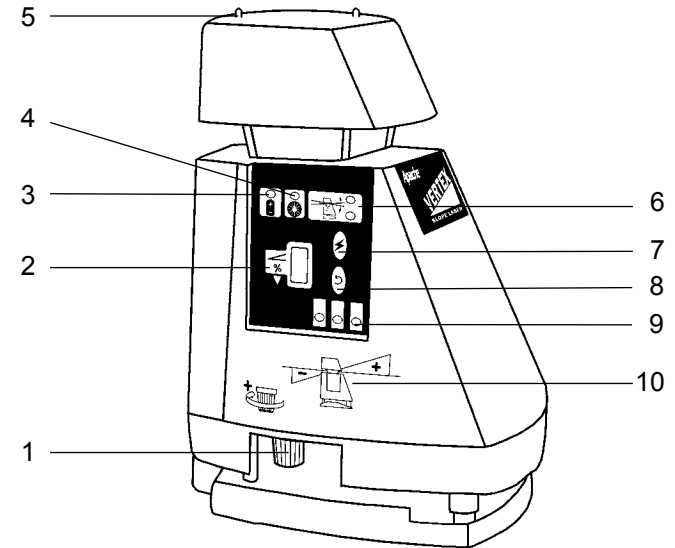

6. H.I. Alert - When the laser finishes leveling and has been running five seconds, the Height of Instrument (H.I.) alert activates. The upper green LED will flash 5 times to confirm activation. If the laser is moved or bumped, or the grade knob is moved sufficiently, the laser beam will shut off, the rotor will stop spinning, and the upper green and lower red LED's will flash alternatively. To clear the H.I. Alert, simply turn the laser off and back on again. Reconfirm the laser beam elevation before continuing your work to avoid errors.

7. Power Switch - Turns the laser on and off.

8. Rotation Speed Switch - select RPM of 600, 900, or 1200. Higher rotation speeds are used with automated machine control systems

9. Rotation Speed Indicators - LED indicates selected speed.

10. Grade Direction and Rotation Symbol - Indicates slope axis positive grade (up) and negative grade (down) directions. Also indicates knob rotation for positive grade.

Controls and Displays

9. **Battery Door** - Cover for battery compartment.
10. **Battery Door Tab** - Pull the tab away from the laser to remove the door and access the battery compartment. Hook the battery door under the metal plate below the lighthouse and push at the base to latch the battery door to the laser.
11. **Battery Charging Jack** - For charging optional rechargeable batteries.

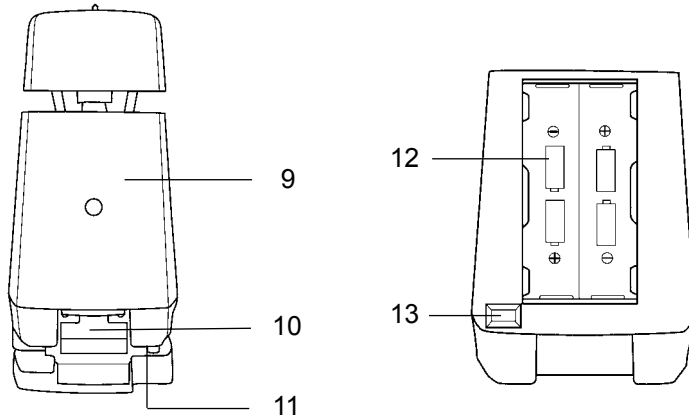

12. **Battery Holder** - Batteries are included with the laser and must be installed for the laser to operate.
13. **Calibration Plug** - Refer to the calibration section in this manual.

Battery Installation

Four "C" cell batteries are provided. Install the batteries as shown in the diagram, noting the "+" and "-" terminals. For reference, there is a diagram molded on the battery holder.

Optional Nickel-Metal Hydride (Ni-MH) batteries and charger are available. Install rechargeable batteries the same as alkalines following the diagram.

Troubleshooting

The laser will not operate, there is no obvious damage:

If the low battery indicator is on, or you suspect the batteries may be dead, replace the batteries. Check the battery contacts to be sure that they are clean.

The receiver shows an on-grade at two different heights:

Check the jobsite for windows or mirrored surfaces that might be reflecting the laser and causing the other reading. Check for others on the site using a rotary laser.

The laser was knocked over:

Visually check the optics for damage. Inspect the laser for any other physical damage. Use the receiver to check that the laser is transmitting. Check the calibration and adjust as needed.

The laser only works at short distances:

Check the output windows for heavy dust or moisture. Remove dust with a camera brush or blow off gently with clean compressed air. Allow moisture to dry.

The receiver does not indicate "on grade" at long distance:

Be sure you are within the maximum distance specification from the laser. Check the windows that surround the rotating mirror on the laser for dust or moisture. Remove dust with a camera brush or blow off gently with clean compressed air. Allow moisture to dry.

Calibration

6. The difference between the two marks (if any) is double the difference between how the laser is calibrated and true level for the cross axis. Half way between these two marks is true level. Make a long mark at true level. If the difference between either outer mark and true level is within your working tolerance, go on to step 10. If not, continue with the next step.

7. Remove the battery door and the rubber plug on the lower left side next to the battery holder. The four buttons control the calibration of the laser. Each push of a button moves the calibration by approximately 3 arc seconds (approx. 1/64" @ 100' / .4mm @ 30m). A small screwdriver, hex wrench, or other small dull device can be used to press the buttons. The label below the opening shows which direction each button will move each axis. Press the "+" or "-" button corresponding to the X axis the number of times estimated to bring the beam to the true level mark. Go to the target surface and check the beam elevation. If the elevation is correct, go to step 8. If not, continue to press the button until the beam comes to the true level mark.

8. Check the cross axis adjustment by rotating the laser back to the first direction and letting the laser re-level. Check that the reading is within the needed tolerance of the true level mark.

9. Rotate the laser 90 degrees to aim the front of the slope axis at the target (+Y axis). Allow the laser to re-level and check the reading at the target. If the reading is on, or within tolerance of the true level mark, calibration is complete. If not, continue to step 10.

10. Verify that the slope display counter is still exactly at 0.00. If not, zero the slope display and recheck the reading. Press the "+" or "-" button corresponding to the Y axis the number of times estimated to bring the beam to the true level mark. Go to the target surface and check the beam elevation. If the elevation is correct, put the rubber plug back in. If not, continue to press the button until the beam comes to level.

Optional Rechargeable Battery Kit

Ni-MH batteries take approximate 10 hours to charge. Recharge after approximately 50 hours of use. To charge, plug the connector into the battery charging jack. Plug the charger into an appropriate outlet. **Never charge alkaline batteries.**

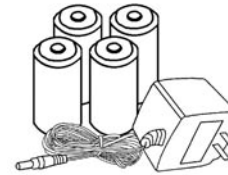

**CHARGE ONLY
RECHARGEABLE
BATTERIES**

Operation

Initial Setup Guidelines

Check Calibration - Although the laser was calibrated at the factory and is exceptionally rugged, it is well worth the effort to check calibration before you first use the laser (after shipping) and then from time to time to ensure that you are doing the highest quality work possible. Always check calibration if the laser has been handled roughly.

Check your setup - It is good jobsite practice when using any laser or optical instrument to check your setup. Use engineered benchmarks on the jobsite to assure that your setup is correct and matches the design of the job. If there are not suitable benchmarks on the site, you can set your own by driving stakes and recording their elevations, or by marking the laser beam height on stable objects such as telephone poles, concrete walls, etc. The benchmarks should be 90 degrees apart for greatest accuracy.

Work Close to the Laser - Although the system can work out to 1650 feet, it is good practice to work as close to the laser as possible. Ensure the laser is mounted in a safe area.

Maintain your Equipment - Keeping tripod and mounting hardware tight, and ensuring grade rods are in good condition can prevent errors and performance problems.

Operation

Level Setup

Set the slope counter display to all zeros (00.00) using the slope adjustment knob. Align the pointer with the red hash mark on the last zero. This sets the laser to level - no slope.

Turn the laser on and allow it to level.

In order to be able to set an accurate zero percent slope, the counter is able to be turned to below zero. When the counter is adjusted to below zero, the upper counter digit will display a "9". This makes it obvious that the slope is set incorrectly and should be changed to zero or to a positive slope setting.

Slope Setup

Follow the suggestions in the "initial setup guidelines" section.

Carefully aim the laser in the direction of slope using the sights on the top cap. These sights align with the direction of slope. The front angled face of the laser should be aimed uphill (as shown on the graphic near the slope adjustment knob.)

Using the slope adjustment knob, adjust the slope display to your required slope. Always dial in positive (+) slope numbers.

Turn the laser on and allow it to level.

Note that if the laser has been on, finished leveling, and the H.I. Alert has become active, you will need to turn the laser off, then on again to clear the H.I. Alert.

The slope counter display reads in percentage. A 2-1/2% slope (projecting upward from the front of the laser) shows as "02.50" on the display. It is the same as a 2.5 foot rise in 100 feet of run.

The % slope can be calculated as follows:

$$\frac{\text{Rise}}{\text{Run}} \times 100 = \% \text{ Slope}$$

Ensure that both the rise and the run are in the same dimension units. For example, both the rise and run must be in feet, not one in feet and one in inches.

Calibration

Calibration is the responsibility of the user - check it often.

Although the laser is calibrated at the factory and are exceptionally rugged lasers, it is well worth the effort to check calibration before you first use your laser (after shipping) and then periodically to ensure that you are doing the highest quality work possible. Always check calibration if the laser has been handled roughly.

Follow the steps below to check the calibration of the laser and make necessary adjustments.

1. Attach the laser to a stable platform or flat head tripod approximately 100 feet from a wall or other stable vertical surface (a telephone pole or concrete building will work well). The vertical surface will be referred to as the "target". The tripod head or platform must be level enough to allow you to turn the laser 360 degrees with minimal re-leveling needed.
2. Rotate the entire laser so that either direction of the cross (X) axis is aimed at the target.
3. Carefully set the slope display counter to 00.00 (The red stripe on the last counter digit should be aligned with the pointer). Turn the laser on and allow it to level.
4. Take the receiver to the target and find the height of the laser beam by moving the receiver up or down until you get a display and/or tone. Find the center of the display and mark the target, using the receiver's beam center notch as a guide. Selecting a narrow deadband on the receiver will speed this process.
5. Return to the laser and rotate it 180 degrees. Allow the laser to re-level. The opposite cross axis (X) direction is now aimed at the target. Find and mark the laser beam height as in step 4.

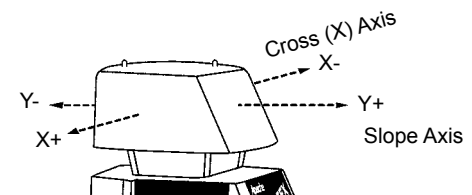

Maintenance and Care

Calibration - There is no set interval for calibrating the laser, but calibration should be checked periodically in order to ensure that the highest possible quality of work is being done. Calibration should always be checked if the laser has been handled roughly or shipped.

Batteries - Occasionally remove the batteries and check the contacts for corrosion. Alkaline batteries will last far longer than carbon batteries. If you use rechargeable batteries, *be careful to never charge alkaline or carbon batteries*. Never run the laser from the charger unless there are rechargeable batteries installed. Keep a spare set of batteries in the carrying case to avoid down time.

Laser output windows - Regularly check the output windows for dust and dirt. Dust can be removed with a camera brush or clean compressed air.

Control panel and exterior - Clean the control panel and the other exterior surfaces of the laser with a soft damp cloth.

Caution - Never store the laser in a carrying case that is wet inside. Moisture can get inside the laser this way. Should this happen, remove the battery cover and place the laser in a warm area until it is completely dry.

Operation

Slope Setup

Down Slope - If a down slope is needed, the slope counter display is set to the required positive slope and the rear of the laser is aimed in the direction of slope. The graphic label just above the slope knob shows the direction that upward or downward slopes are projected and the proper direction to turn the knob to increase or decrease the slope.

NOTE: Do not set negative slope into the counter. The upper counter digit will turn to "9" indicating an error.

Steep Slope - When using the laser at slope settings over 14%, you will need to tilt the tripod to allow the laser to level. By aligning the laser so that one tripod leg is to the rear (down slope side), you can shorten that leg to tilt the tripod head and the setup will remain stable.

Regularly check your setup against benchmarks. If none are present, set at least two of your own to monitor the accuracy of your setup.

The laser can be set at an offset to the ditch. Just be sure to point the sights on the top cap parallel to the direction of the slope.

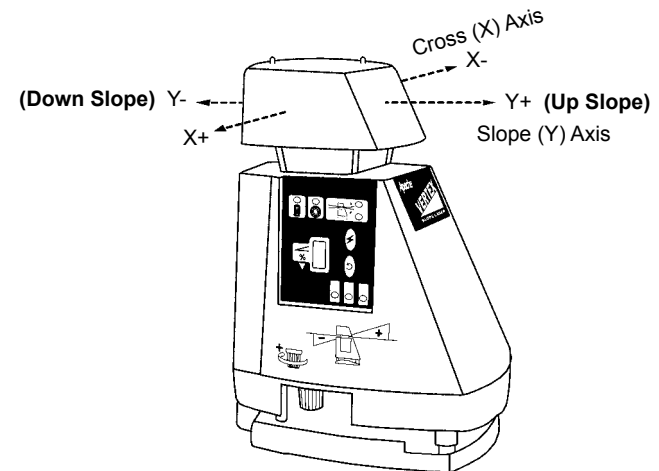

Operation

Compound Slope Setup

Compound Slope - When a site design has slope in two directions, 90 degrees apart, the Compound Slope Adapter Kit can be used to calculate and set the laser to the designed compound slope. A resultant slope - different from the 2 original slopes - is set at an angle across the site to give the desired slope in two directions.

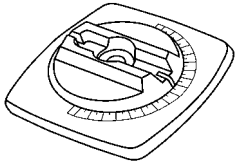

In order to begin a compound slope setup, the Compound Slope Adapter must be installed on the laser. If not installed, follow the instructions included with the kit. Next, follow these steps:

1. Determine the two slopes for the site and the direction of each slope. Set the compound slope adapter angle to zero (0) degrees and aim the laser parallel to the main slope on the site (the main slope is the steeper of the two slopes). Be certain that the up-slope direction of the laser is aimed uphill on the main slope. If there is any question which is the up slope direction for the laser, you can refer to the label on the side of the laser just above the slope adjustment knob.
2. Find the two slopes for the site on the chart supplied with the kit and follow their row and column until they intersect. Remember that the main slope is the steeper of the two slopes. The upper number in the box where the two slopes intersect is the angle to set into the adapter. The lower number is the resultant slope to dial into the laser's slope counter. Note: The slope number is displayed with greater precision than the slope counter increments.
3. Rotate the adapter until the alignment slot matches the angle determined with the slope chart. Note: if, when standing behind the laser, the highest corner on the site is to the right of the grade sight, you must rotate the adapter counter-clockwise until you reach the proper reading. If the high corner is to the left, you must rotate the adapter clockwise.

Operation

Compound Slope Setup

4. Turn the entire laser toward the uphill direction of the cross slope (toward the highest corner on the site) until the slope alignment sight is once again aligned parallel to the main slope. The laser is now at the proper angle.
5. To finish the setup, dial in the resultant slope determined from the chart and go to work. Note: you can recheck the setup at any time by doing the following: A. Verify the slope counter setting. B. Verify that the proper angle is set into the compound slope adapter. C. Verify that the slope alignment slot is parallel with the main slope direction. D. Verify that the uphill direction of the laser is aimed toward the high corner of the site.

Always set at least two grade checking stakes that are 90 degrees apart so that you can verify the laser setup from day to day on the site.

Compound slope example

1. Zero the compound slope adapter ring and aim the laser parallel to the main slope, with the up-slope direction of the laser aimed uphill on the site.
 2. Lookup the intersection of the main slope (.25) and the cross slope (.15) using the slope chart. The box at the intersection looks like this:
- | |
|-------|
| 31 |
| 0.292 |
3. Turn the adapter alignment slot 31° counterclockwise.
 4. Turn the entire laser to realign the alignment slot parallel with the main slope. (The laser is now aimed 31° toward the high corner).
 5. Dial the resultant slope of .29% into the slope counter. Setup is complete.

